

Supplemental type certificate (STC) kits – Winnipeg, MB

SMOOTHLY NAVIGATE
YOUR INSTALLATION
TO CERTIFICATION

Comprehensive product and service
expertise from aircraft integration specialists

SIMPLIFY YOUR PROGRAM WITH STRENGTH IN NUMBERS

When it comes to a smooth, timely, step-by-step process for certifying equipment for your program, experience counts. As one of Canada's largest and most capable Design Approval Organizations, we process hundreds of design approval projects for supplemental type certification.

Whether you're looking for a ready-made solution or a fully customized supplemental type certificate (STC) kit, we provide a comprehensive source for the engineering, manufacturing and certification of new aircraft solutions. Our simple, ready-to-install kits help reduce maintenance and operational costs. We also develop fully customized kits across a wide range of platforms to meet your specific requirements.

Over the years, we've successfully navigated through certification processes and built relationships with global airworthiness authorities. Our experienced Transport Canada Civil Aviation (TCCA), Federal Aviation Administration (FAA) and European Aviation Safety Agency (EASA) representatives have an extensive understanding of OEM system type integration. You can count on them to provide comprehensive certification solutions for your program requirements. And with in-house engineering support and specialists, we offer options for customized integration engineering and multinational approvals.

Review our existing kits or contact us for a tailored solution to ensure a smooth upgrade for your program.

Equipment experience

- In-flight entertainment
- Cabin management system
- SATCOM
- VVIP interior completion
- Layout of passenger accommodations reconfiguration
- Aircraft communications, addressing and reporting system (ACARS)
- Wireless local area network
- Class II electronic flight bag
- Flight management system
- Terrain awareness and warning system (TAWS) and enhanced ground proximity warning system (EGPWS)
- GPS
- Emergency locator transmitter (ELT)
- Traffic collision avoidance system (TCAS/Mode-S)
- Interior/exterior lighting

Platform experience

Airbus

ATR

BAE Systems

Beechcraft

Beechjet

Boeing

Bombardier

CASA

Cessna

Dornier

Embraer

Eurocopter

Fokker

Hawker Beechcraft

Lockheed Martin

McDonnell Douglas

Pilatus

Saab

Sino-Swearingen



Additional services

- FAA-designated engineering representative, designated airworthiness representative and designated manufacturing inspection representative service
- Parts Manufacturer Approval (PMA) and consulting
- Installations and parts certification
- Avionics and electrical system design
- Occupant safety assessment
- Flammability testing
- Aircraft structures stress and damage tolerance analysis
- Interior engineering
- EASA Form 1 airworthiness tag
- EASA production organization approval facility installation kit provision

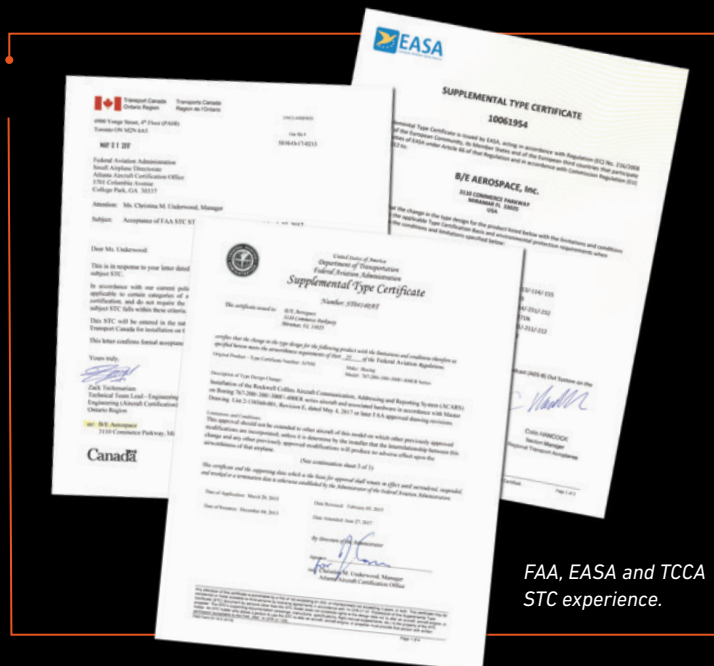

FAA, EASA and TCCA STC experience.

INDEX

APU air inlet rain gutter	C46231-3	6
Improved Beechcraft 200 floor panels	K26811	7
Baggage door safety catch	956931-3	8
Q400 LED tail light	03-9200-200X	9
Lav/Galley water heater replacement kit	G37331	10
Cabin recirculation air filter	C46031-4/-5/-6	11
Cabin recirculation HEPA filter installation kit	C460KL21001-1	12
Crew oxygen indicating system	C44231-1/-3	13
Crew oxygen remote fill	C21631-3	14
Flap actuator heating system	G16831-1	15
Ladder plate repair kit	RD8-L/HREPAIR, RD8-R/HREPAIR	16
ECS manual control cold limit clamp	C46431-1/-3	17
Flight deck cooling systems	A74750-1, A74750-3, B44731-1	18
CRJ flight deck manual stowage box	F846031-1/-3	20
Dash-8 flight deck manual stowage box	B78631-7/-9	21
Ground power circuit breakers	D11931-1	22
Ground power service bus-cargo light	G36931-1	23
Ground power service bus	C12031-101/-201/-3	24
Improved aft jet pipe support	C54642-1/-2	25
Improved exhaust shroud	A23831-103	26
Improved fingernail joint seal	D12431-1/D12432-1	27
Logo light installation kit	C93631-5	28
Improved take-off configuration warning system	C46331-1/-3	29
LED lavatory light	E99831-1	30
Level of Service (LOS) annunciator driver	H123001-1	31
Replacement crew seat backrest panel	D23131-3	32
Rechargeable flashlight	C99431-1/-3	33
Tow guard installation	H235102-1	34

C46231-3

APU AIR INLET RAIN GUTTER

Prevent ingestion of fluid by the APU –

The APU Inlet Rain Gutter helps to prevent ingestion of rain or de-icing fluids by the APU. Installed on the right-hand side of the aircraft behind the aft pressure bulkhead, this aluminum 'J'-section gutter diverts fluids away from the APU air inlet.



SPECIFICATIONS

Applicability	All DHC-8-100/-200/-300 aircraft equipped with APU
Labor	Approximately six hours
Kit contents	<ul style="list-style-type: none"> • Gutter • Spacer • Blind rivets
Weight	Increase of 0.6 lbs.
Certification	<ul style="list-style-type: none"> • Transport Canada SA00-5 • Netherlands* SA 0012NL • FAA ST01172NY
Delivery	F.O.B. Winnipeg, Canada

FEATURES AND BENEFITS

- Avoidance of rain or de-icing fluid ingestion by the APU air inlet
- No interior access or removal of the APU is necessary other than for removal of metal chips

*Approved for 213 series only.

K26811

IMPROVED BEECHCRAFT 200 FLOOR PANELS

These floor panels are designed to deliver a durable and quality replacement to existing floor panels that have disbonded and have begun to feel 'soft' when walking on them. These floor panels replace the three center aisle-way panels in the aircraft and are designed to hold up to a higher volume of foot-traffic than the originals.

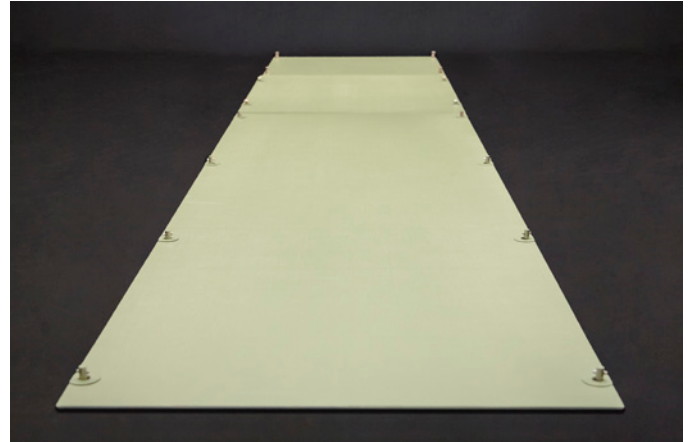

SPECIFICATIONS

Applicability	Beechcraft King Air 200s with OEM floor panels
Kit contents	Three replacement floor panels for cabin center aisle-way
Lead time	4-6 weeks delivery
Weight	Equivalent
Certification	• Transport Canada SA15-48
Delivery	F.O.B. Winnipeg, Canada

FEATURES AND BENEFITS

- Longer life-span
- Additional stiffness
- Increased load-carrying capability
- Retained installation hardware for direct and interchangeable replacements
- Proven and conventional aluminum honeycomb construction
- Constant-thickness cross-section throughout to eliminate disbonding of skins on edges

956931-3

BAGGAGE DOOR SAFETY CATCH

Increased ease of operation and safety – Collins' baggage door safety catch replaces the existing baggage door strut. The baggage door safety catch automatically engages when the baggage door is raised to either the fully open or half-open position and is quickly and easily disengaged by the pull of a handle.

SPECIFICATIONS

Applicability	All DHC-8-100/-200/-300 series
Labor	Approximately 16 hours, not including access and close-out
Kit contents	<ul style="list-style-type: none"> • Catch assembly • Safety stop block • Intermediate stop block • Release handle assembly • Lanyard • Installation hardware • Parts list
Weight	Equivalent
Certification	<ul style="list-style-type: none"> • Transport Canada SASA91-97 • EASA EASA.IM.A.S.03177 • FAA SA1013NE • Germany TA0290
Delivery	F.O.B. Winnipeg, Canada

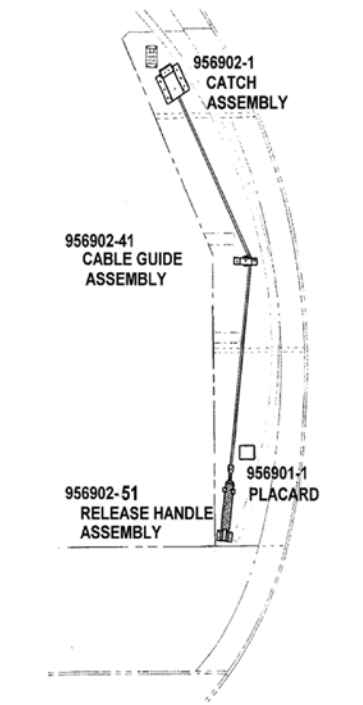

FEATURES AND BENEFITS

- Can be safely operated from the ground
- Automatically engages when door is raised
- Easily disengaged by the pull of a handle
- Lanyard provided for easy means of closing the door

03-9200-200X Q400 LED TAIL LIGHT

Improved reliability and longer life span – Collins' LED
Q400 tail light uses state-of-the-art optics and chip-on-board technology. Increased reliability and a higher mean time between failures (MTBF) means less time lost on the ground, decreased maintenance costs, and less inventory needed.



SPECIFICATIONS

Mechanical	
Dimensions	1.65" x 4.07" (42 x 103.5 mm)
Weight	0.51 lbs. (0.23 kg)
Electrical	
Operating voltage	28VDC
Current draw	12W
Optical	
Intensity	Meets FAR23/25/ 27/29.1391/1393/ 1395/1397 *
Color	Aviation White

*Measurements taken at 36" away. All values nominal.

FEATURES AND BENEFITS

- Improved reliability and longer life than xenon or halogen products
- Integrated power supply eliminates need for external power supply
- FAA/EASA TSO C30c (position light)
- Meets RTCA-DO-160 D standards
- Rugged design to withstand environmental factors
- LED replacement for current halogen and xenon light assemblies on Dash-8 Q400 aircraft

G37331

LAV/GALLEY WATER HEATER REPLACEMENT KIT

Provide flights with higher air purity – Installing a high-efficiency particulate air (HEPA) filter enables you to filter cabin recirculation air before it reaches the condenser mixer.

Currently, air is drawn from the cabin and passes through the prefilter, capturing large contaminant particles PM10 and PM2.5. Our HEPA filter kit is an addition to the installation filter kit C46031-4/-5/-6 and includes both a prefilter and HEPA filter.

Both filters are mounted together inside an aluminum enclosure and easily slide into the existing filter box. Together, the prefilter and HEPA filter elements are designed to remove and trap at least 99.97% of the harmful airborne particles that have a diameter of 0.3 micron. These include pollen, dust, mites and airborne bacteria.

The filters are removable for periodic replacement.

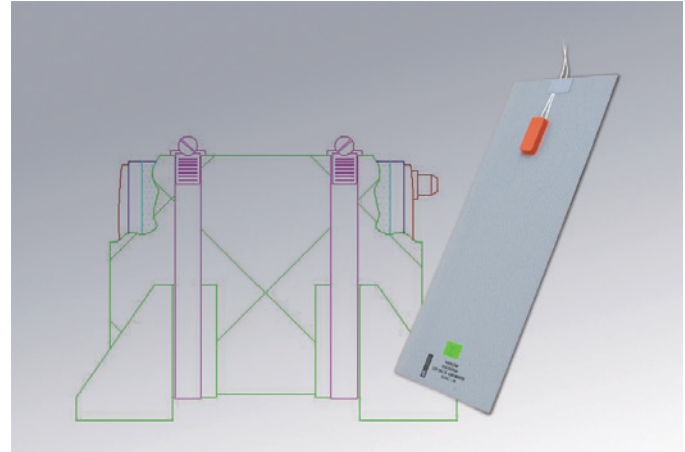

SPECIFICATIONS

Applicability	Bombardier CL600-1A11/-2A12/-2B16
Labor	Equivalent to six-month required inspection
Kit contents	<ul style="list-style-type: none"> • Heating element • Insulation covering
Weight	Equivalent
Certification	<ul style="list-style-type: none"> • Transport Canada SA10-9 • EASA 10029833 • FAA ST02786NY
Delivery	F.O.B. Winnipeg, Canada

FEATURES AND BENEFITS

- Replaces heating and insulating components of KC Aviation P/N 444-0007
- Eliminate potential overheating and scalding hazards
- Provide relief of Service Bulletin inspection
- No need to replace existing tank
- Uses existing electrical connections with no electrical modifications needed

C46031-4/-5/-6

CABIN RECIRCULATION AIR FILTER

Increased airflow and extended lifespan – This solution provides a means to filter cabin recirculation air before it reaches the condenser mixer. Currently, air is drawn from the cabin where it is mixed with fresh air and passed through the heat exchanger before being distributed back to the cabin. Because the cabin air is laden with dust, this causes blockage of the condenser mixer, leading to reduced or no recirculation airflow and reduced life of ECS parts.

To remedy this situation, our filter is designed to insert into the recirculation duct, upstream of the recirculation blower fan. The filter is mounted inside an aluminum sheet metal box that is attached to the floor beneath the aft right-hand seat. The filter element, which is designed to trap dust before it reaches the heat exchanger, is easy to remove from the box for periodic cleaning or replacement.



SPECIFICATIONS

Applicability	DHC-8 Series 100 and 300 post-1990, Hunting and C&D interiors and 200 series all interiors*
Labor	Approximately six hours, including access and close-out if RH aft cabin floor panel is pre-modified
Kit contents	<ul style="list-style-type: none"> • Filter box assembly with filter • Installation brackets and hardware • Maintenance manual supplement • Illustrated parts catalogue supplement • Ducting
Weight	<ul style="list-style-type: none"> • 6.5 lbs. – 4 kit • 7.5 lbs. – 5 kit • 8.0 lbs. – 6 kit (20 lbs. of ducting removed prior to installation)
Certification	<ul style="list-style-type: none"> • Transport Canada: SA01-65 • EASA: EASA.IM.A. S.02429 • FAA: ST01375NY • Japan: STC-47-HQT • Angola: Letter of Acceptance
Delivery	F.O.B. Winnipeg, Canada

FEATURES AND BENEFITS

- Reduces potential blockage of the condenser mixer
- Promotes peak performance of the ECS system
- Reduces maintenance costs associated with ECS system cleaning

KIT OPTIONS

- C46031-4: Installation Kit Dash-8 (-100/-200) post-1990
- C46031-5: Installation Kit Dash-8 (-300; 50 PAX) post-1990
- C46031-6: Installation Kit Dash-8 (-300; 52/56 PAX) post-1990

*Applicable to 300 series with 50-seat cabin and left-hand aft seats at between station 550.5 and 572.0 or between station 572.0 and 600.0.

Applicable to 300 series with 52- or 56-seat cabin and left-hand aft seats at between station 572.0 and 600.0.

C460KL21001-1

CABIN AIR RECIRCULATION HEPA FILTER INSTALLATION KIT

Provide flights with higher air purity – Installing a high-efficiency particulate air (HEPA) filter enables you to filter cabin recirculation air before it reaches the condenser mixer.

Currently, air is drawn from the cabin and passes through the prefilter, capturing large contaminant particles PM10 and PM2.5. Our HEPA filter kit is an addition to the installation filter kit C46031-4/-5/-6 and includes both a prefilter and HEPA filter.

Both filters are mounted together inside an aluminum enclosure and easily slide into the existing filter box. Together, the prefilter and HEPA filter elements are designed to remove and trap at least 99.97% of the harmful airborne particles that have a diameter of 0.3 micron. These include pollen, dust, mites and airborne bacteria.

The filters are removable for periodic replacement.

SPECIFICATIONS

Part number	C460KL21001-1
Applicability	DHC-8 Series 100, 200 and 300 (Post 1990) Hunting and C&D interiors and 200 series all interiors
Certification	Transport Canada: SA01-65 STC
Efficiency	99.97% on 0.3 micron particles
Labor	Approximately 10 minutes to replace and install the new filter kit
Installation	Slides directly into the existing filter box
Kit contents	Filter pack aluminum enclosure with one prefilter and one HEPA filter
Recommended replacement interval	C-check based on the actual condition inspected at every A-check
Delivery	F.O.B Winnipeg, MB, Canada

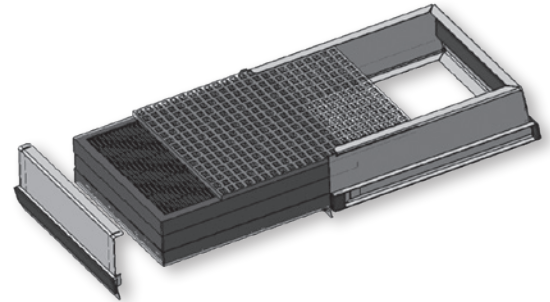

Prefilter and HEPA filter together in aluminum casing

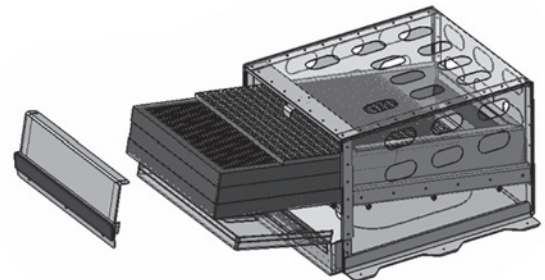

Prefilter and HEPA filter installation in existing filter box

FEATURES AND BENEFITS

- Conveniently designed to slide directly into the pre-existing filter box
- Highly effective at trapping microscopic contaminants such as bacteria, viruses and other airborne contaminants in ECS system
- Designed as a retrofit unit for Dash-8 (-100/-200/-300) aircraft
- Low replacement cost for the prefilter and HEPA filter elements (part number C460PZ21001-1)
- Includes an updated IPC and AMM supplement

C44231-1/-3

CREW OXYGEN INDICATING SYSTEM

Upgrade to an electronic gauge – The crew oxygen electronic indicating system replaces the mechanical repeater pressure gauge with an electronic gauge. The gauge is mounted in the same location on the flight deck and is fed pressure signals by a transducer threaded onto the existing gauge port at the bottle head.

The modification eliminates most of the mechanical “plumbing” associated with crew oxygen system leakage, and allows for easy removal of the bottle for refill further reducing leakage.

The electronic gauge mounts in the same location without modification. The wiring is secured using existing copper tube plumbing provisions.

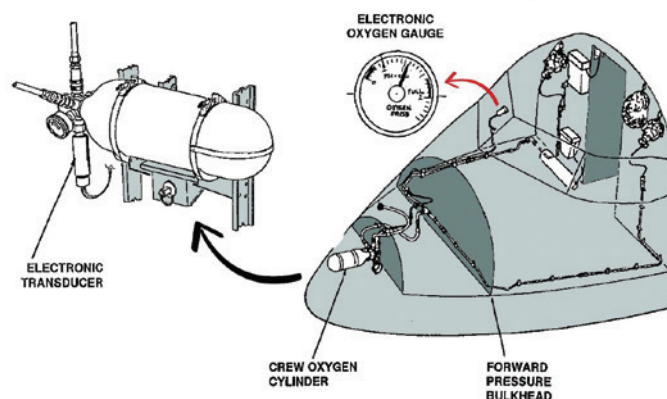

SPECIFICATIONS

Applicability	All DHC-8-100/-200/-300/-400 aircraft with standard 39 ft3 crew oxygen bottle installation
Labor	Approximately 16 hours, not including access and closure
Kit contents	<ul style="list-style-type: none"> • One electronic oxygen contents gauge • One electronic transducer • Electrical connectors for gauge and transducer • Bulkhead penetration fitted
Weight	Increase of 2.5 lbs.
Certification	<ul style="list-style-type: none"> • Transport Canada: SA99-271 • FAA: ST01168NY • Norway: 200005869-2/712/ANM • Netherlands:* SA 0011 NL
Delivery	F.O.B. Winnipeg, Canada

FEATURES AND BENEFITS

- Makes it easier to remove bottle
- Eliminates most potential leaks

KIT OPTIONS

- C44231-1 – Installation Kit (-100/-200/-300)
- C44231-3 – Installation Kit (-400)

*Approved for -300 Series only.

C21631-3

CREW OXYGEN REMOTE FILL

Readily accessible remote fill valve – Eliminate the need to remove crew oxygen bottles for refilling and greatly reduce the leakage occurrence rate.

The crew oxygen remote fill modification adds a remote fill valve to the RH lower nose compartment. It is installed adjacent to the crew oxygen bottle and connected by copper tubing to the bottle head refill port.

Easily refill the crew oxygen bottle by opening the RH lower access door, removing the dust cap from remote fill valve, attaching to oxygen source, and refilling per normal procedures.

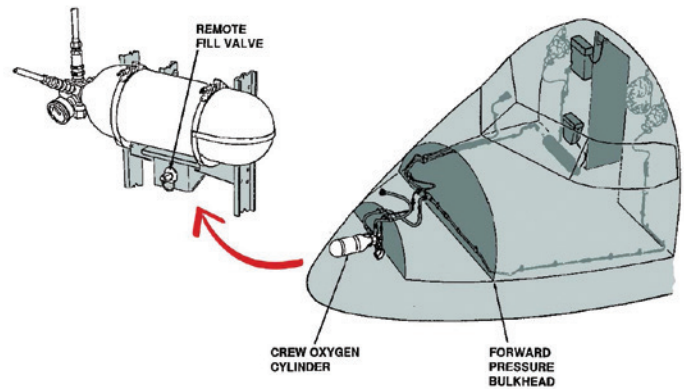

SPECIFICATIONS

Applicability	All DHC-8-100/-200/-300/-400 aircraft with standard 39 ft ³ crew oxygen bottle installation
Labor	Approximately six hours, not including access and closure
Kit contents	<ul style="list-style-type: none"> • Remote fill valve • Oxygen tubing and fittings • Mounting bracket kit
Weight	Increase of 0.6 lbs.
Certification	<ul style="list-style-type: none"> • Transport Canada¹: SA99-245 • FAA¹: ST01166NY • German LBA²: TA0291 • Norway¹: 200005 320-3/712/ANM • Spain³: 243-S • Netherlands³: SA 0017 NL • Austria⁴: ACG.21NE.007 • UK CAA¹: AAN No.27605 • Aruba¹: DL1500185
Delivery	F.O.B. Winnipeg, Canada

¹Approved for -100/-200/-300/-400 Series

²Approved for -100/-200/-300 Series

³Approved for -300 Series

⁴Approved for -100/-300 Series

FEATURES AND BENEFITS

- No need to remove crew oxygen bottle from aircraft
- Remote fill valve is readily accessible
- Eliminate system leaks caused by disrupting the tubing

G16831-1

FLAP ACTUATOR HEATING SYSTEM

Reduce overall load on flap actuator system – The flap actuator system on the CRJ200 has been plagued by overloading due to cold temperatures. Airworthiness Directives are costly and do not solve the root cause of system failures.

The Collins Aerospace system provides controlled heat to the actuator housing via a custom designed heater, increasing the operating temperature at lower ambient temperatures. This heater reduces system torque dramatically.

The system is controlled by a cockpit annunciator, turned on at the start of operation. The system automatically regulates itself in relation to measured ambient temperature.

Long-term plans include application to provide an alternate means of compliance (AMOC) to Airworthiness Directives 2009-06-12 (FAA) and CF-2007-10 (TCCA) regarding the failure of the flap system, which may result in some relief to the requirements of the subject Airworthiness Directives.

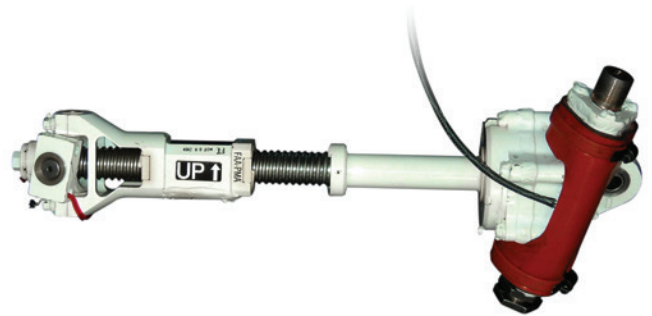

SPECIFICATIONS

Applicability	CRJ200 aircraft
Labor	Approximately 150 hours*
Kit contents	<ul style="list-style-type: none"> • Eight actuator heaters • Heater controller assembly • Replacement glareshield panel and annunciator • Wiring assembly and components
Weight	Approximately 3.5 lbs. increase
Certification	<ul style="list-style-type: none"> • FAA: ST03032NY • Transport Canada: SA11-54 • EASA: STC Pending
Delivery	F.O.B. Winnipeg, Canada

*Hours can vary greatly due to amount of available access to aircraft; installation during regular maintenance checks is recommended.

FEATURES AND BENEFITS

- Reduces overall load on flap actuator system
- Reduces chance of system overload, and flap failure events
- Reduces temperature fluctuation of the actuator housing, the amount of air expansion/contraction and the lubricant contamination

RD8-L/HREPAIR, RD8-R/HREPAIR LADDER PLATE REPAIR KIT

All you need for ladder plate repair – Collins' Ladder plate repair kit offers all formed and machined components needed, including Hi-Lok fasteners for ladder plate repair according to De Havilland generic repair RD8-57-876. This kit is applicable in repair of cracked ladder plates that are part of the upper wing skin that occurs in the in-board, aft corner of the inner access opening adjacent to wing station Yw= 139.20.

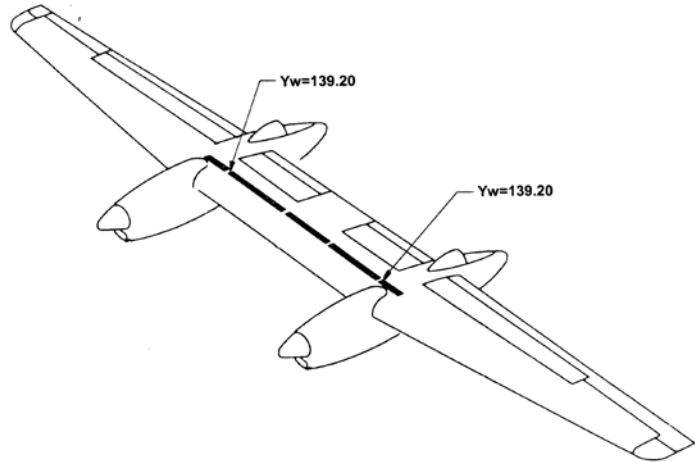

SPECIFICATIONS

Applicability	DHC-8-102/-103, post-mod 8/0024
Installation	Full instructions are found in RD8-57-876
Kit contents	<ul style="list-style-type: none"> • External doubler (RD-1/-2) • Cutout filler (RD-3/-4) • Corner packer (RD-5/-6) • Internal repair doubler (RD-7/-8) • Packers (RD-9/-10/-11) • Bushing, minimum (RD-12; Qty. 3) • Bushing, medium (RD-12; Qty. 3) • Bushing, large (RD-12; Qty. 3) • Angle (RD-13/-14) • Bolt (NAS4404-9; Qty. 17) • Hi-Lok bolts and collars (Qty. 274; oversized stocked)
Approval status	RD8-57-876; Bombardier approved repair
Manufacturing and distribution	Collins Aerospace is a Transport Canada approved AWM 561 manufacturer and AWM 573 AMO
Delivery	F.O.B. Winnipeg, Canada

FEATURES AND BENEFITS

- Kit includes everything needed to replace the ladder plate surrounding a crack on the upper wing skin on DHC-8-102/-103
- Bombardier approved repair
- All parts can be ordered as a kit or individually

KIT OPTIONS

- RD8-L/HREPAIR Parts kit (LH wing)
- RD8-R/HREPAIR Parts kit (RH wing)

C46431-1/-3

ECS MANUAL CONTROL COLD LIMIT CLAMP

Avoid damage caused by cold temperatures – This certified cold clamp limit STC introduces a circuit that detects an impending low-temperature condition that could potentially cause the air entering the cabin to fall below freezing and allow frost to collect in the condenser, blocking airflow or causing damage to the ACM unit. The STC kit circuit disables additional manual control selection and automatically applies a gradual warmer command to the temperature control system to bring cabin air supply temperatures back up above freezing.



SPECIFICATIONS

Applicability	DHC-8-100/-200/-300
Labor	Approximately 24 hours, not including access and closeout
Kit contents	<ul style="list-style-type: none"> • Cold clamp relay bracket • Temperature switch(s) • Mounting kit • Wiring kit • Maintenance manual supplement • Illustrated parts catalogue supplement
Weight	Approximately 2 lbs. increase
Certification	<ul style="list-style-type: none"> • Transport Canada: SA00-109 • EASA: EASA.IM.A.S.03022 • FAA: ST01297NY • Japan: STC-46-HQT • Angola: Letter of Acceptance
Delivery	F.O.B. Winnipeg, Canada

FEATURES AND BENEFITS

- Enhances temperature control in Manual Mode
- Reduces possibility of ice build up in the system
- Reduces potential damage to ACM

KIT OPTIONS

- RD8-L/HREPAIR Parts kit (LH wing)
- RD8-R/HREPAIR Parts kit (RH wing)

A74750-1, A74750-3, B44731-1 FLIGHT DECK COOLING SYSTEMS

A flight deck cooling system aids in reducing flight crew fatigue – a major factor and concern in the extremely intense operations associated with fire-bombing with the Canadair CL-215.

SPECIFICATIONS

Applicability	<ul style="list-style-type: none"> CL-215-1A10 and CL-215-6B11 (Keith Products A/C mod) CL-215-6B11 (Casey Copter to Keith A/C mod) CL-215-1A10 (Improved Ram-air ventilation system)
Manufacturing	Collins Aerospace is a Transport Canada approved AWM 561 manufacturer and AWM 573 AMO
Certification	<p>CL-215 (CL-215-1A10)</p> <ul style="list-style-type: none"> Transport Canada: SA99-227 FAA: ST01425NY <p>CL-215T (CL-215-6B11)</p> <ul style="list-style-type: none"> Transport Canada: Pending FAA: Pending
Delivery	F.O.B. Winnipeg, Canada

FEATURES AND BENEFITS

- Reduced crew fatigue
- Increased crew comfort
- All wiring data, electrical connectors, and other components provided (installer provides wire)
- Full air conditioning and Ram-air ventilation includes addition of a cabin air outlet – allows passengers to be carried with retardant foam (equivalent to Canadair SB215-469)

KIT OPTIONS

A74750-1 – Flight Deck Cooling System kit, CL-215 (CL-215-1A10);

A74750-3 – Flight Deck Cooling System kit, CL-215T (CL-215-6B11);

B44731-1 – Air conditioning Upgrade kit, CL-215T (CL-215-6B11); Includes:



- Bulk aluminum tubing, end fittings and materials for refrigerant line fabrication
- Compressor/condenser installation shelf, air inlet duct and exhaust shroud
- Fresh air and recirculated air plenum assembly and control handle
- Fresh air inlet scoop and distribution ducting
- Four flight deck eyeball vents and distribution ducting
- One passenger compartment eyeball vent and installation components
- Structural provision kit for fuselage penetrations
- Anchor relocation kit
- Electrical connectors, relays and other components, including soft-start kit
- Bombardier supplied compressor/condenser, evaporator/blower, and control panel
- Installation drawings, system charging/testing procedures and maintenance instructions
- Transport Canada approved FMS allowing passengers with retardant foam on board

D04731-1 – Improved Ram-air Ventilation kit, CL-215 (CL-215-1A10); Includes:

- Fresh air inlet scoop and distribution ducting
- Four flight deck eyeball vents and distribution ducting
- One passenger compartment eyeball vent and installation components
- Structural provision kit for fuselage penetrations
- Installation drawings
- Transport Canada approved FMS allowing passengers with retardant foam on board

INSTALLATION

CL-215 – Full air-conditioning and **CL215T** – Full air-conditioning

A Keith Products Inc, CL-415 type, compressor/condenser (Bombardier P/N 215T95645-4, modified by installer) is mounted to the airframe at RH FS 352 to FS 371, inside the cabin.

The shroud-enclosed assembly is attached between fuselage frames using braces from aluminum sheet metal components. Two cut-outs are made in the fuselage to facilitate cooling air inlet and exhaust ducts for the compressor/condenser.

A Keith Products Inc, CL-415 type, evaporator/blower (Bombardier P/N 215T95644-4) is bolted to the floor in the bow compartment, RH side. The existing anchor installation is relocated to the LH side of the bow compartment. A fiberglass plenum assembly attached to the evaporator/blower permits selection of fresh air or recirculated air by means of a pedestal mounted control knob.

An electrical control panel (Bombardier P/N 215T51538-2 (CL-215) or P/N 215T51523 (CL-215T), modified by installer) is mounted in the flight deck overhead panel for air conditioning system control and blower fan speed.

The aluminum tubing refrigerant lines running between the compressor/condenser and the evaporator/blower are attached with aluminum brackets and cushion clamps down the RH side of the cabin and beneath the flight deck floor.

A fiberglass air scoop is added to the fuselage skin just aft of the flight deck (RH side) to provide fresh ram air. Flexible fiberglass reinforced ducting, routed beneath the flight deck floor, attaches the air scoop to the evaporator/blower plenum. Rigid and flexible ducting distributes air to four eye-ball type vents on the lower edge of the instrument panel, and one air outlet in the cabin.

A Keith “soft start” kit added to the compressor compensates for motor high starting current.

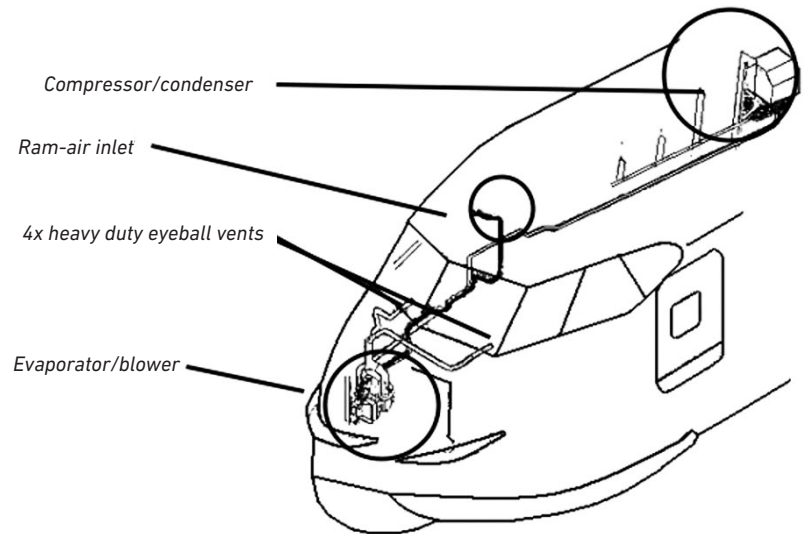

CL215T – Air-conditioning upgrade kit

Existing Casey Copter compressor/condenser and evaporator/blower are replaced with the Keith type, as installed on the CL-415. Four eyeball vents on the instrument panel replace existing ducting and outlets. Existing refrigerant lines are modified to connect to Keith type compressor/condenser and evaporator/blower. The existing electrical installation is modified to connect to CL-415 type compressor/condenser and evaporator/blower.

CL215 – Improved Ram-air ventilation

A fiberglass air scoop is added to the fuselage skin just aft of the flight deck (RH side) to provide fresh ram air. Flexible fiberglass reinforced ducting, routed beneath the flight deck floor, attaches the air scoop to rigid and flexible ducting, that distributes air to four eyeball type vents on the instrument panel, and one air outlet in the cabin.

F846031-1/-3

CRJ FLIGHT DECK MANUAL STOWAGE BOX

Operating manual storage for the CRJ – Collins' flight deck manual stowage box safely houses aircraft operating manuals and ensures accessibility to both members of the flight crew during flight via an access panel located in the flight deck floor, aft of the center console. When not in use, the box lid forms part of the flight deck floor.

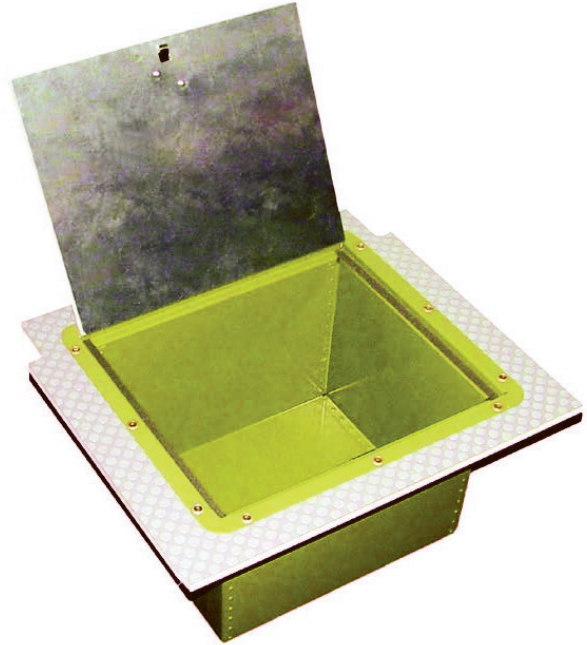

SPECIFICATIONS

Applicability	CL601/-604/-850, CRJ100/-200/-440
Labor	Approximately two hours
Kit contents	<ul style="list-style-type: none"> • Stowage box assembly • Mounting hardware • Floor panel
Weight	8.7 lbs. increase
Certification	<ul style="list-style-type: none"> • Transport Canada: SA10-111 • FAA: ST02957NY
Delivery	F.O.B. Winnipeg, Canada

FEATURES AND BENEFITS

- Safely houses aircraft operating manuals
- Manuals accessible to both crew members in flight
- Frees up flight deck space
- Can be customized to house other flight deck items such as spare headsets
- Easy removal for access to the equipment and electrical bay
- Floor panel included in the kit directly replaces the aircraft floor panel

KIT OPTIONS

- F846031-1 Installation kit CRJ100/-200/-440, CL850
- F846031-3 Installation kit CL605

B78631-7/-9

DASH-8 FLIGHT DECK MANUAL STOWAGE BOX

Operating manual storage for the Dash-8 – Collins' flight deck manual stowage box safely houses aircraft operating manuals and ensures accessibility to both members of the flight crew during flight via an access panel located in the flight deck floor, aft of the center console. When not in use, the box lid forms part of the flight deck floor.



SPECIFICATIONS

Applicability	DHC-8-100/-200/-300/-400
Labor	Approximately eight hours. If spare access panel present, most can be installed with no downtime.
Kit contents	<ul style="list-style-type: none"> • Stowage box assembly • Qty. 8 threaded inserts • Qty. 8 mounting screws
Weight	Increase of 8.7 lbs.
Certification	<ul style="list-style-type: none"> • Transport Canada: SA98-60 • FAA: ST00886NY • EASA: 10034865 • Norway: 200102290-3/321/ANM • UK CAA: AAN No. 28149 • Austria¹: ACG.21NE.009 • Netherlands¹: SA-0025-NL • Spain²: S283-I • Croatian STC: UP/1 343-05/09-01/328
Delivery	F.O.B. Winnipeg, Canada

¹Approved for -100/-300 series only

²Approved for -315/-400 series only

FEATURES AND BENEFITS

- Safely houses aircraft operating manuals
- Manuals accessible to both crew members in flight
- Frees up flight deck space
- Can be customized to house other flight deck items such as spare headsets

KIT OPTIONS

- B78631-7 Installation kit
- B78631-9 Installation kit

D11931-1

GROUND POWER CIRCUIT BREAKERS

Quick reset capabilities – Collins' ground power circuit breakers for Dash-8 aircraft replace the existing F3 and F4 current limiters with resettable, high-current, thermal circuit breakers. These circuit breakers alert air or ground crew to a fault that has caused one or more of the ground power circuit breakers to trip by interrupting the current to the EXT PWR AVAIL. These circuit breakers can be manually reset by maintenance crew without the need for additional tools. The new circuit breakers are mounted to the forward face of the D.C. contactor box, requiring some structural modifications to the box and cover.

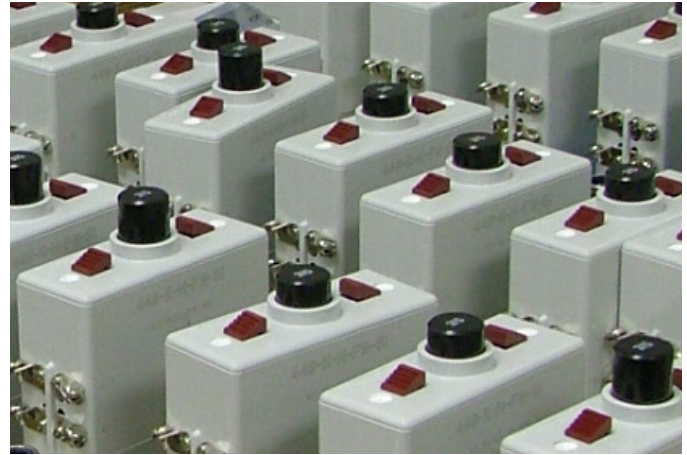

SPECIFICATIONS

Applicability	DHC-8-100/-200/-300
Labor	Approximately eight hours
Kit contents	<ul style="list-style-type: none"> • 315A circuit breaker (2) • Size 0 lead assembly (2) • Copper links (6) • Mounting plates, covers, hardware • Replacement interior and exterior D.C. contactor box legends • Maintenance manual supplement
Weight	Increase of approximately 7 lbs.
Certification	<ul style="list-style-type: none"> • Transport Canada: SA02-127 • FAA: ST01563NY • EASA: 10042346 • Spain: S309-1 • Austria: ACG.21NE2.108 • Aruba: DL 1500185
Delivery	F.O.B. Winnipeg, Canada

FEATURES AND BENEFITS

- Provides quick reset capability without need for tools or replacement parts
- Provides cockpit annunciation of loss or ground power
- Avoids unintentional battery starts in the event of current limiter failures
- Access to LH nose compartment and interior of D.C. contactor box required

G36931-1

GROUND POWER SERVICE BUS-CARGO LIGHT

Add functionality of a cargo light without energizing the whole aircraft – Collins' ground power service bus-cargo light addition adds functionality of the cargo light when the aircraft is powered by the Collins Aerospace ground power service bus, enabling the light to be used for any cleaning or maintenance activities in the baggage compartment without the need to energize the entire aircraft electrical system. The C12031 ground power service bus kit must already be installed to add this kit.



SPECIFICATIONS

Applicability	DHC-8-100/-200/-300 with Collins Aerospace ground power service bus previously installed in accordance with TCCA SA99-216/FAA ST00998NY
Labor	Approximately 12 hours
Kit contents	<ul style="list-style-type: none"> • 20A circuit breaker • Pre-marked wiring • Terminals • Release certification TCCA Form One • Approval and installation documentation
Weight	Increase of approximately 1 lb.
Certification	<ul style="list-style-type: none"> • Transport Canada: C-LSA09-334/DISS1 • FAA: STC Pending • EASA: STC Pending
Delivery	F.O.B. Winnipeg, Canada

FEATURES AND BENEFITS

- Power to cargo light available on-ground without the need to energize all systems
- Enhanced safety for ground maintenance activities
- Removal of maintenance panels and flight deck trim panels for access
- No removal of flight deck or cabin equipment required

C12031-101/-201/-3

GROUND POWER SERVICE BUS

Power without energizing the whole aircraft – The ground power service bus modification will allow the operator to use the cabin overhead lighting, airstair door light, and position lights during ground operations without energizing the complete aircraft electrical system.

The ground power service bus is controlled by the GND SERV POWER switch, located on the LH DC circuit breaker panel. The bus is energized by momentary selection of the GND SERV POWER switch ON position. The switch is spring loaded to the center position.

The ground power service bus may be manually turned OFF by momentary selection of the GND SERV POWER switch to OFF position. The ground power service bus will automatically be turned OFF by any the following conditions:

- Disconnection or deactivation of the DC ground power unit
- Manual selection of External Power to ON
- Over-voltage condition of the DC ground power unit

When the ground power service bus is OFF, the loads listed above (interior lights and position lights) will revert to their normal power source. Because the ground power service bus is enabled only when a DC ground power unit is connected, and is automatically disabled when external power is selected to ON, no flight crew control or monitoring of the bus is required.

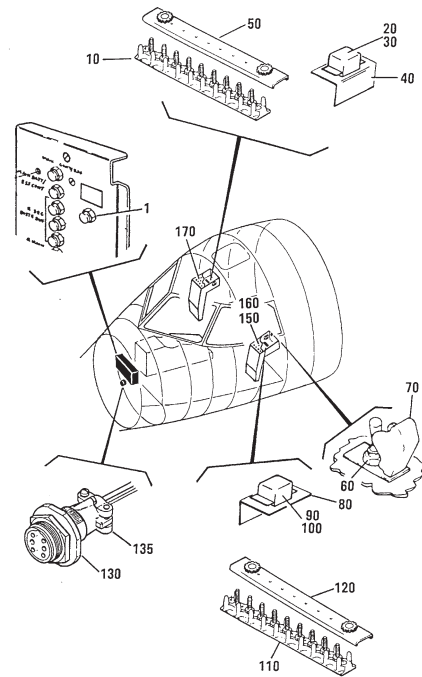

SPECIFICATIONS

Applicability	DHC-8-100/-200/-300
Labor	Approximately 50 hours
Kit contents	<ul style="list-style-type: none"> • Guarded control switch • Harness assembly with pre-wired relay socket and terminal block (2) • Relay (2) • 35A, 30A, 20A (2) circuit breakers • Receptacle and plug • Pre-marked wiring • Terminals, splices etc.
Weight	Increase of 4.8 lbs.
Certification	<ul style="list-style-type: none"> • Transport Canada: SA99-216 • FAA: ST00998NY • German LBA: TA0292 • Spain¹: Letter of Acceptance • Netherlands¹: SA 0010 NL • Austria²: ACG.21NE.008 • Aruba: DL-1500185
Delivery	F.O.B. Winnipeg, Canada

FEATURES AND BENEFITS

- Selected cabin systems are powered without energizing the entire aircraft
- Increase in avionics and electrical component life
- Enhanced safety for ground maintenance activities
- Removal of maintenance panels and flight deck trim panels for access
- No removal of flight deck or cabin equipment required

KIT OPTIONS

- C12031-101 – Installation kit (-100)
- C12031-201 – Installation kit (-200)
- C12031-3 – Installation kit (-300)

¹DHC-8-300 only

²DHC-8-100/-300 only

C54642-1/-2

IMPROVED AFT JET PIPE SUPPORT

Proven reduction in wear – Collins' improved aft jet pipe support reduces wear of the bearing track surface. This new bearing track is composed of a more resilient material more able to withstand high friction and temperature. These bearing tracks replace bearing track 87800091-001/-002.

Collins' bearing tracks are manufactured using the investment casting process with an added casting factor when determining section thickness to ensure adequate strength. Dimensionally critical surfaces are machined to size.

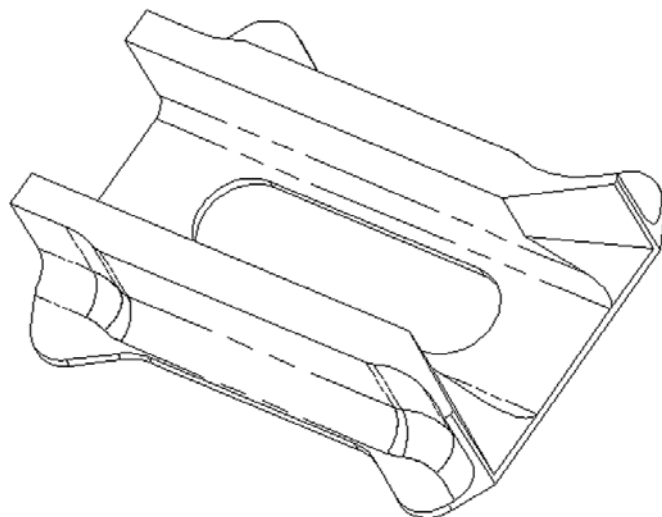

SPECIFICATIONS

Applicability	DHC-8-100/-200/-300
Labor	Equivalent to removal of exhaust shroud and jet pipe per standard maintenance procedures, replacement of jet pipe supports, and reinstallation of jet pipe and exhaust shroud
Kit contents	<ul style="list-style-type: none"> • C54642-1 LH Track • C54642-2 RH Track • Rivets (8)
Weight	0.18 lb. increase per track
Certification	<ul style="list-style-type: none"> • Transport Canada: SA01-77 • FAA: ST01387NY • EASA: 10040686 • Austria: ACG.21NE2.084
Delivery	F.O.B. Winnipeg, Canada

FEATURES AND BENEFITS

- Significant reduction in acquisition cost
- Significant reduction in maintenance costs
- Prolonged life of jet pipe, support components and exhaust outlet shroud
- Low coefficient of friction
- Resistant to seizing and galling
- New materials allow sliding contact with other metals without metal pick up
- Resists heat and oxidation
- Retains hardness even at red heat

A23831-103

IMPROVED EXHAUST SHROUD

Longer life, less maintenance – Collins Aerospace has designed a modification to the shroud assembly which, in combination with portions of DHC mod 8/1664 and production-line only mod 8/2062, addresses thermally induced buckling and the associated cracking.

Operators have experienced problems with thermally induced distortion, buckling and eventual cracking of portions of the exhaust shroud. These problems have often required maintenance activities prior to completion of the normal “C” check interval. Other problems observed include formation of cracks in the supporting side angles and frame assemblies that may also chafe the underlying structure.

These problems have been found to be related to thermal stress and thermal fatigue, which may be amplified when lengthy periods of ground idling are an operational factor. Collins’ proven exhaust shroud replacement addresses these issues, and offers operators the option of sending removed exhaust shroud assemblies to its facility, in Winnipeg, for modification and repair or delivery of a kit.

SPECIFICATIONS

Applicability	All DHC-8-100/-200/-300
Labor	Approximately 80 hours; fast turn times have resulted from an extensive use of support fixtures and a large inventory of mod and repair parts
Kit contents	<ul style="list-style-type: none"> • Forward shroud • Aft shroud • Nacelle skin panels (LH & RH) • Structural angles, channels, straps, etc. • Drawings and documents
Weight	Weight change negligible
Certification	<ul style="list-style-type: none"> • Transport Canada: SA95-67 • FAA: ST00389NY • EASA: EASA.IM.A.S.02326 • Japan: STC-5-HQT • Egypt: Letter of acceptance • Angola: Letter of acceptance • Spain: 267-S • Austria: FL428-1/117-97
Delivery	F.O.B. Winnipeg, Canada

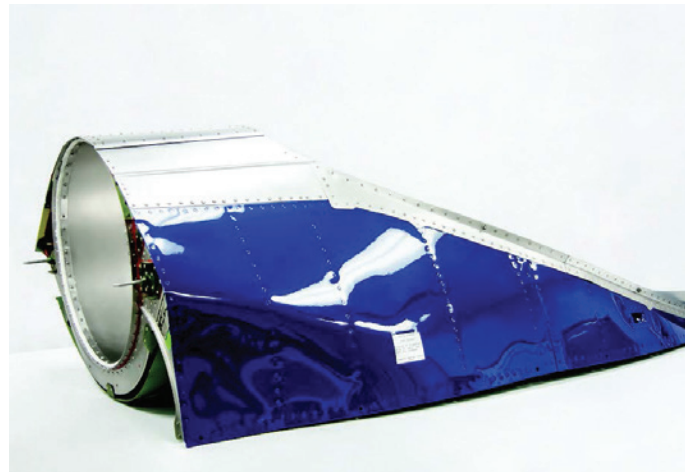

FEATURES AND BENEFITS

- Significant reduction in maintenance
- Prolonged life of exhaust shroud
- Modified exhaust shrouds have withstood over 10,000 hours in service with no unscheduled maintenance, minor repairs, and without removal from aircraft

D12431-1/D12432-1

IMPROVED FINGERNAIL JOINT SEAL

Reduce exhaust gas leakage – Collins' improved fingernail joint seal reduces exhaust gas leakage into fire zones 3 and 4 via a redesigned seal at the interface between the nacelle closing structure and fingernail assembly and an exhaust shroud extension incorporating a double seal. The exhaust shroud telescopes into the fingernail assembly, providing a heat shield to protect the forward section and reduce buckling. Collins' modification kit includes a new, redesigned forward fingernail section.



SPECIFICATIONS

Applicability	DHC-8-100/-200/-300
Labor	Part A: done at Collins Aerospace's Winnipeg facility (STC SA95-67) Part B: approximately eight hours
Kit contents	Part A: <ul style="list-style-type: none"> Fingernail forward shroud Retainer (2) Part B: <ul style="list-style-type: none"> Exhaust shroud extension Seal assembly
Weight	Approximate increase of 1 lb. per nacelle
Certification	<ul style="list-style-type: none"> Transport Canada: SA02-5 FAA: ST01484NY
Delivery	F.O.B. Winnipeg, Canada

FEATURES AND BENEFITS

- Reduces exhaust gas leakage underneath fingernail (fire zone 4)
- Reduces exhaust gas leakage into main landing gear bay (fire zone 3)
- Reduces buckling of the fingernail tunnel and side skins

MODIFICATIONS

- Removal of a seal and retainer from the aft face of the nacelle closing structure
- Removal of a high temperature seal and straps from the fingernail assembly
- Removal of the forward section of the fingernail assembly – these are replaced with a redesigned seal at the interface between the nacelle closing structure and the fingernail assembly

KIT OPTIONS

- D12431-1 Installation Kit, Part A
- D12432-1 Installation Kit, Part B

C93631-5

LOGO LIGHT INSTALLATION KIT

Improved logo light featuring an LED array – This model has been designed to provide even more in-service reliability than the existing LED logo lights. Improvements include cooler operating temperatures and significantly more illumination than its predecessors. The latest generation LED logo light is a direct replacement for the OEM incandescent lamp and is fully interchangeable with the original LED Logo Lights (P/N C93631-7/-9).

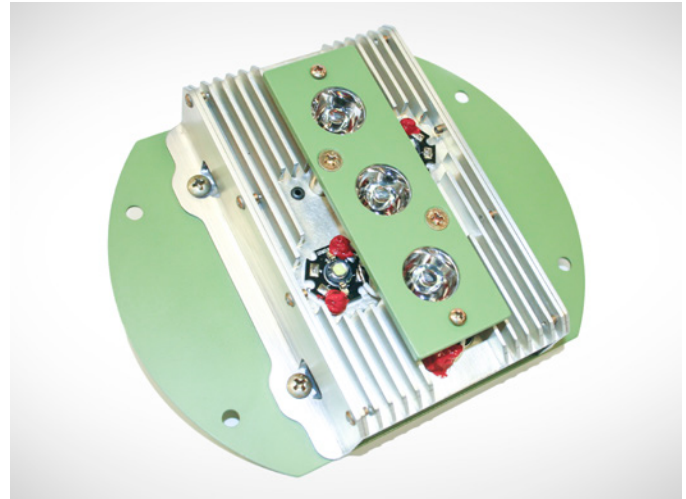

SPECIFICATIONS

Applicability	All CRJ Series 100/200 with Bombardier factory installed logo light option
Labor	Approximately two hours, including access and closure
Kit contents	<ul style="list-style-type: none"> • Logo light assembly • Installation drawing and maintenance supplement
Electrical	<ul style="list-style-type: none"> • 20VA (max) at 27VAC
Weight	A slight increase of 0.6 lbs. per array
Certification	<ul style="list-style-type: none"> • Transport Canada: SA02-4 • FAA: ST01468NY • EASA: EASA.IM.A.S.03023
Delivery	F.O.B. Winnipeg, Canada

FEATURES AND BENEFITS

- Long life
- Maintenance costs reduced by \$1.25 (U.S.) per flight hour
- Safety improved due to low heat output
- Inventory reduction – replacement bulbs in stock not required
- Improved reliability of logo light transformer

C46331-1/-3

IMPROVED TAKE-OFF CONFIGURATION WARNING SYSTEM

Increase dispatch reliability – Collins' improved take-off configuration warning system helps reduce attempts to take off with the nose landing gear down latch safety mechanism engaged.

DHC-8-100 – This modification provides a test switch to simulate engine take-off throttle position. If the aircraft is not correctly configured for take-off when the test switch is pressed, the warning horn will activate. As an additional parameter, not included on any series Dash-8, the nose landing gear down latch safety mechanism position is monitored by means of a micro-switch. If the mechanism is not stowed and locked to allow free movement of the nose landing gear, the warning horn will activate when the test switch is pressed.

DHC-8-200/-300 – Since the DHC-8-200 and -300 come equipped with a means to check take-off configuration at low engine power settings, a partial installation kit provides an upgrade to include the monitoring of down latch safety mechanism position.

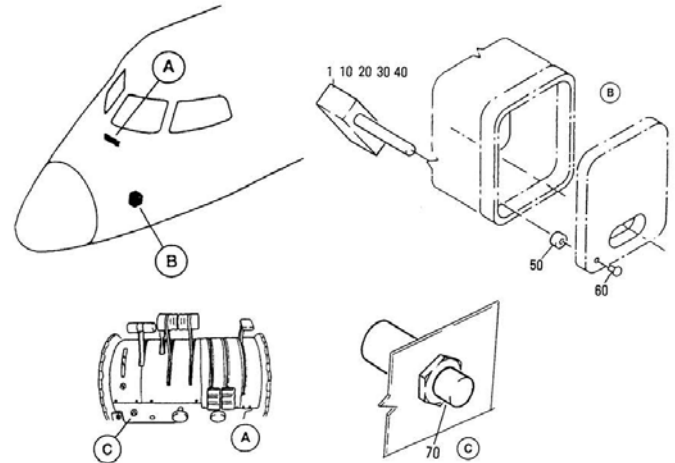

SPECIFICATIONS

Applicability	All DHC-8-100/-200/-300 aircraft
Labor	Approximately 20 hours (excludes access and closure)
Kit contents	<p>DHC-8-100</p> <ul style="list-style-type: none"> • Throttle console mounted test switch • Safety latch housing mounted micro-switch • Installation fasteners • Wiring kit <p>DHC-8-200/-300</p> <ul style="list-style-type: none"> • Safety latch housing mounted micro-switch • Installation fasteners • Wiring kit
Weight	Increase of 0.5 lb.
Certification	<ul style="list-style-type: none"> • Transport Canada: SA00-70 • FAA: SA01249NY • UK CAA: AAN No. 27606
Delivery	F.O.B. Winnipeg, Canada

FEATURES AND BENEFITS

- Increased dispatch reliability
- Decreased canceled take-off clearance

KIT OPTIONS

- C46331-1 Installation kit (-100)
- C46331-3 Installation kit (-200/-300)

E99831-1

LED LAVATORY LIGHT

Reduce power draw with LED lavatory lighting – Collins supplies an LED lavatory light assembly to replace the existing compact fluorescent tube light assembly and ballast. The LED lavatory light assembly consists of an adapter plate assembly (to be mounted using existing hardware), LED light assembly, three standoffs, and mounting hardware. In addition, the existing lens and its hardware are re-usable. The LED light assembly is easily mounted and wired into the existing location and is operated at 50% illumination until the lavatory is occupied – at which time, 100% illumination will be activated with the light switch.

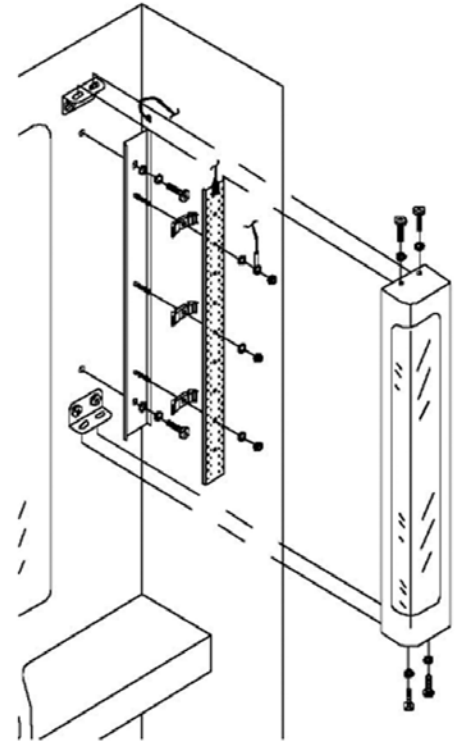

SPECIFICATIONS

Applicability	DHC-8-400
Labor	Eight hours, including access and close-out
Kit contents	<ul style="list-style-type: none"> • Adapter plate assembly • LED light assembly • Standoff (3) • Installation hardware • Parts list Terminals, splices etc.
Weight	Approximately equivalent
Certification	<ul style="list-style-type: none"> • Transport Canada: SA10-25 • FAA: ST02949NY • EASA: 10032519
Delivery	F.O.B. Winnipeg, Canada

FEATURES AND BENEFITS

- Greatly extended service life (5,000 hours plus)
- Connected to existing 28VDC aircraft power
- Offers stepped dimming capability with two levels of intensity, 50% or 100%
- Can be connected directly into 28VDC aircraft power
- Reduced power consumption (13W fluorescent to 10.9W LED)

H123001-1

LEVEL OF SERVICE (LOS) ANNUNCIATOR DRIVER

Increase range while decreasing delays – Collins' LOS Annunciator Driver Unit (LADU) interfaces with the Garmin Wide Area Augmentation Systems (WAAS) and allows the Garmin GPS systems to drive external annunciators indicating the WAAS approach LOS. The LADU facilitates the use of Garmin GPS systems in the aircraft by reading the LOS status from the GPS ARINC port and driving the related LOS annunciators on the pilot and copilot instrument panels. Required DAO expertise as well as project and program management are provided by Collins Aerospace.



SPECIFICATIONS

Compatibility	Compatible w/ these Dual Garmin WAAS GPS units: <ul style="list-style-type: none"> • GPS-400W/500W series • GNC-420W-520W series • GNS-430W/530W series • GTN-625/650 series • GTN-725/750 series
Kit contents	<ul style="list-style-type: none"> • LOS Annunciator Driver Unit • Pilot and Copilot annunciators (optional) • Electrical connectors and mounting hardware
Weight	8.7 lbs. (3.95 kg)
Certification	<ul style="list-style-type: none"> • Transport Canada: Pending • FAA: STC Pending • EASA: STC Pending
Delivery	F.O.B. Winnipeg, Canada

FEATURES AND BENEFITS

- WAAS Technology allows for instrument approaches to small and/or isolated airports, decreasing delays and weather cancellations
- Low cost alternative to other WAAS navigation options

D23131-3

REPLACEMENT CREW SEAT BACKREST PANEL

Stronger, more flexible backrests – The existing pilot and copilot seat backrest panels on both PC-12 and PC-45 aircraft become damaged in service and require frequent changes. The Collins Aerospace replacement crew seat backrest panel is manufactured from a composite prepreg (pre-impregnated) material for increased comfort and reliability.

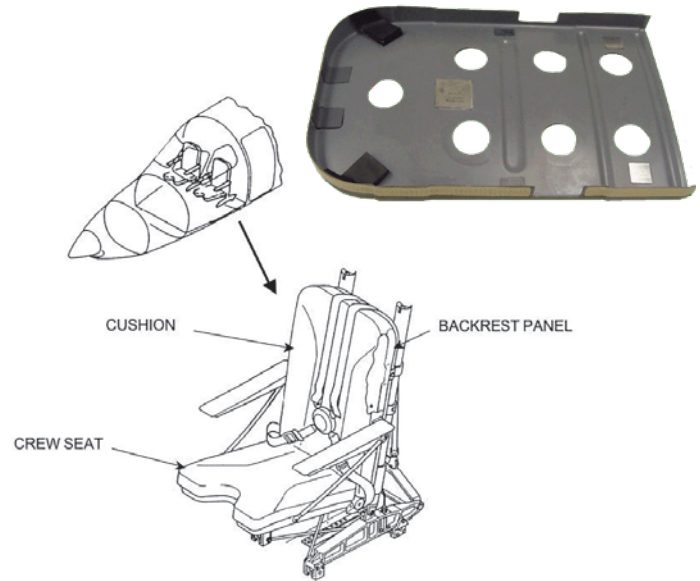

SPECIFICATIONS

Applicability	All Pilatus PC-12/45 aircraft
Kit contents	<ul style="list-style-type: none"> • STCs (Canadian & FAA) • Modification data summary (master drawing list) • Installation drawing • Replacement panel assembly
Weight	Weight change negligible; 1.81 lbs. (0.8 kg) per panel
Certification	<ul style="list-style-type: none"> • Transport Canada: SA03-10 • FAA: SA01627NY • EASA: Pending
Delivery	F.O.B. Winnipeg, Canada

FEATURES AND BENEFITS

- Greater strength while keeping the panel flexibility
- Addition of three ribs for greater comfort and panel stiffness
- Addition of stainless steel doublers at three locations to protect the seat panel from existing seat frame screws that rub against the panel

INSTALLATION

- The original backrest panel is removed and the replacement panel is installed over the tubular seat frame using the existing mounting fasteners.

C99431-1/-3

RECHARGEABLE FLASHLIGHT

A bright, rechargeable light – The rechargeable flashlight modification introduces Ni-Cad battery powered units that are mounted in place of existing flashlights, using existing mounting provisions while replacing the existing configuration of non-rechargeable flashlights mounted in the flight deck at each crew location and at the forward and aft flight attendant stations. The rechargeable flashlights deliver 3000 candle-power for up to 45 minutes and can be re-charged 1000 times. Full depletion recharge time is 16 hours.

Recharging of the Ni-Cad batteries occurs at all times when the aircraft is powered and the flashlight is secured in its mount. Recharging power is obtained from the 28VDC system. Short electrical leads are provided to connect flashlight mounts to forward and aft flight attendant panels, pilot's CB panel and co-pilot's CB panel.

Two versions of the modification kit contain either three or four rechargeable flashlights to suit flight attendant station configuration in the user's aircraft.



SPECIFICATIONS

Applicability	All CRJ100/200 with Bombardier factory installed non-rechargeable flashlight (P/N P2-07-0001-214)
Labor	Approximately eight hours
Kit contents	<ul style="list-style-type: none"> • 3 or 4 flashlights with mounts • Interconnecting lead assemblies • Mounting hardware • Adhesive kit • Installation drawing and maintenance supplement
Weight	Equivalent
Certification	<ul style="list-style-type: none"> • Transport Canada: SA01-95 • FAA: ST01465NY
Delivery	F.O.B. Winnipeg, Canada

FEATURES AND BENEFITS

- Bright, serviceable flashlight always available to flight and cabin crew
- Maintenance costs per flight hour slightly reduced
- Inventory reduction – replacement batteries not required
- All mounting provisions and hardware remain unchanged from the existing flashlight installation

KIT OPTIONS

- C99431-1 Installation Kit (3 flashlights)
- C99431-3 Installation Kit (4 flashlights)

H235102-1

TOW GUARD INSTALLATION

Tow guard installation for CRJ-100/200/440

– The CRJ-100/200/440 is type certified for tow-barless towing operations. The Tow Guard is installed directly above the retaining ring of the nose landing gear shock strut and provides a retaining area for the tow strap.

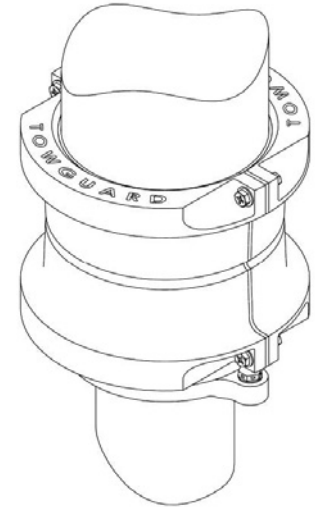

SPECIFICATIONS

Applicability	CRJ-100/200/440
Labor	Approximately one hour
Kit contents	<ul style="list-style-type: none"> • Tow guard assembly • Installation drawing and maintenance supplement
Weight	Increase of 2.0 lbs.
Certification	<ul style="list-style-type: none"> • Transport Canada: SA12-21 • FAA: Pending • EASA: Pending
Delivery	F.O.B. Winnipeg, Canada

FEATURES AND BENEFITS

- The Tow Guard reduces the tendency for the Nose Landing Gear Sensors to be damaged during tow-barless towing operations.

To learn more, go to

→ collinsaerospace.com/stc-interiors

Collins Aerospace

+1.204.783.5402

fax: +1.204.783.5436

sales.canada@collins.com

collinsaerospace.com