

# C21631-3

## Crew oxygen remote fill

**Readily accessible remote fill valve** – Eliminate the need to remove crew oxygen bottles for refilling and greatly reduce the leakage occurrence rate.

The Crew oxygen remote fill modification adds a remote fill valve to the RH lower nose compartment. It is installed adjacent to the crew oxygen bottle and connected by copper tubing to the bottle head refill port.

Easily refill the crew oxygen bottle by opening the RH lower access door, removing the dust cap from remote fill valve, attaching to oxygen source, and refilling per normal procedures.

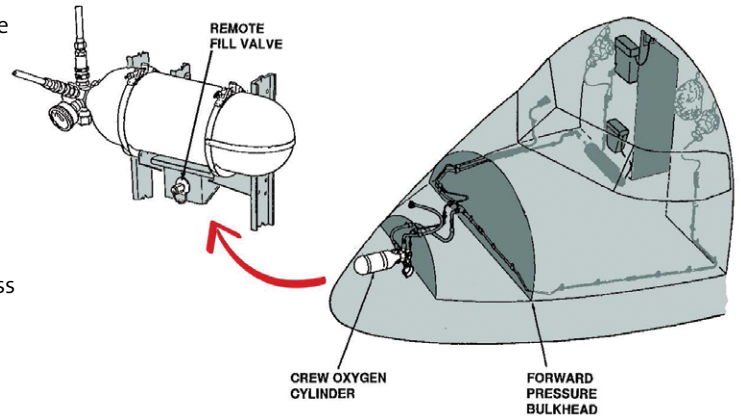

### SPECIFICATIONS

Applicability	Manpower	Kit contents	Weight	Certification	Delivery
All DHC-8-100/-200/-300/-400 aircraft with standard 39 ft <sup>3</sup> crew oxygen bottle installation	Approximately 6 man-hours, not including access and closure	<ul style="list-style-type: none"> <li>&gt; Remote fill valve</li> <li>&gt; Oxygen tubing and fittings</li> <li>&gt; Mounting bracket kit</li> </ul>	Increase of 0.6 lbs.	<ul style="list-style-type: none"> <li>&gt; Transport Canada<sup>1</sup>: SA99-245</li> <li>&gt; FAA<sup>2</sup>: ST01166NY</li> <li>&gt; German LBA<sup>2</sup>: TA0291</li> <li>&gt; Norway<sup>1</sup>: 200005 320-3/712/ANM</li> <li>&gt; Spain<sup>3</sup>: 243-S</li> <li>&gt; Netherlands<sup>3</sup>: SA 0017 NL</li> <li>&gt; Austria<sup>4</sup>: ACG.21NE.007</li> <li>&gt; UK CAA<sup>1</sup>: AAN No.27605</li> <li>&gt; Aruba<sup>1</sup>: DL1500185</li> </ul>	F.O.B. Winnipeg, Canada

### FEATURES & BENEFITS

- > No need to remove crew oxygen bottle from aircraft
- > Remote fill valve is readily accessible
- > Eliminate system leaks caused by disrupting the tubing

<sup>1</sup>Approved for -100/-200/-300/-400 Series

<sup>2</sup>Approved for -100/-200/-300 Series

<sup>3</sup>Approved for -300 Series

<sup>4</sup>Approved for -100/-300 Series

### Building trust every day.

Rockwell Collins delivers innovative aviation and high-integrity solutions that transform commercial and government customers' futures worldwide. Backed by a global network of service and support, we are deeply committed to putting our solutions to work for you, whenever and wherever you need us. In this way, working together, we build trust. Every day.

### For more information, contact:

Rockwell Collins  
Lighting & Engineered Solutions  
25 Dunlop Avenue,  
Winnipeg, MB Canada R2X 2V2  
ph: +1.204.783.5402  
fax: +1.204.772.7568  
rockwellcollins.com



Building trust every day