

H235102-1 Tow guard installation

Tow guard installation for CRJ-100/200/440 –
The CRJ-100/200/440 is type certified for tow-barless towing operations. The tow guard is installed directly above the retaining ring of the nose landing gear shock strut and provides a retaining area for the tow strap.

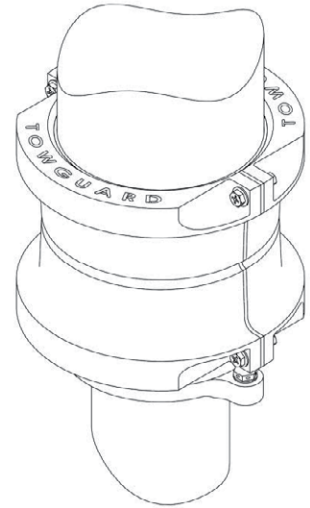
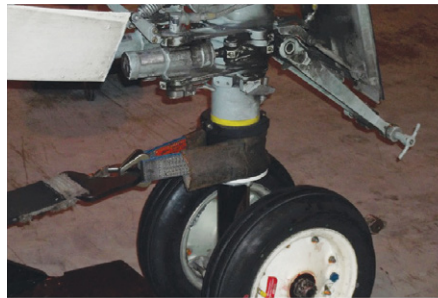

SPECIFICATIONS

Applicability	Manpower	Kit contents	Weight	Certification	Delivery
CRJ-100/200/440	Approximately 1 man-hour	<ul style="list-style-type: none"> > Tow guard assembly > Installation drawing and maintenance supplement 	Increase of 2.0 lbs.	<ul style="list-style-type: none"> > Transport Canada: SA12-21 > FAA: Pending > EASA: Pending 	F.O.B. Winnipeg, Canada

FEATURES & BENEFITS

- > The Tow Guard reduces the tendency for the Nose Landing Gear Sensors to be damaged during tow-barless towing operations.

Building trust every day.

Rockwell Collins delivers innovative aviation and high-integrity solutions that transform commercial and government customers' futures worldwide. Backed by a global network of service and support, we are deeply committed to putting our solutions to work for you, whenever and wherever you need us. In this way, working together, we build trust. Every day.

For more information, contact:

Rockwell Collins
Lighting & Engineered Solutions
25 Dunlop Avenue,
Winnipeg, MB Canada R2X 2V2
ph: +1.204.783.5402
fax: +1.204.772.7568
rockwellcollins.com



Building trust every day