

THIS DOCUMENT AND THE INFORMATION IT CONTAINS IS THE PROPERTY OF EMTEQ INC. AND MAY NOT BE USED IN ANY WAY WITHOUT THE EXPRESS WRITTEN CONSENT OF EMTEQ INC.

REV	REVISION	DATE	ER #	INTL
IR	INITIAL RELEASE	02/12/2010	10540	VML

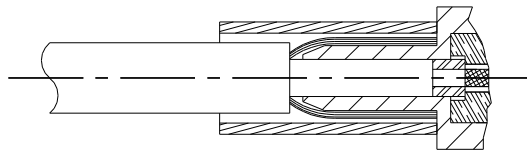
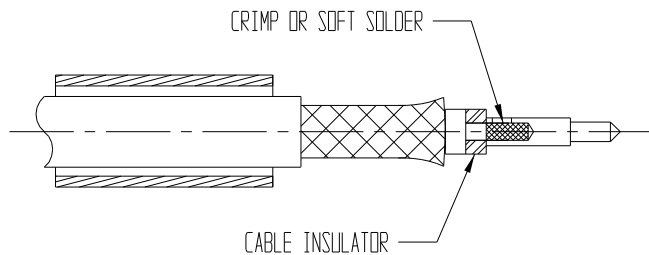
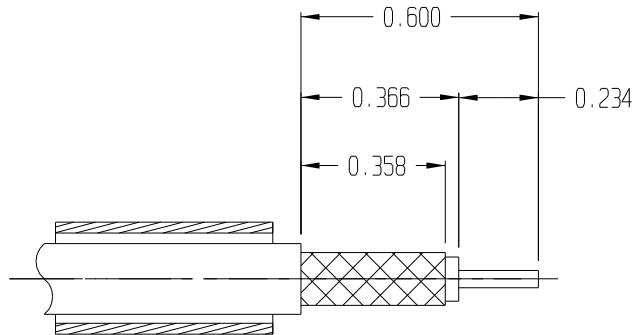

ES-105-65
CABLE ASSEMBLY INSTRUCTIONS

- 1.) SLIDE ON ANY HEAT SHRINK LABELS IF USED, THEN THE BLACK ADHESIVE HEAT SHRINK AND THEN THE CRIMP TUBE.
- 2.) STRIP THE CABLE PER THE DIMENSIONS SHOWN. REMOVE THE MATERIALS.
- 3.) INSTALL THE CABLE INSULATOR ONTO THE CENTER CONDUCTOR BUTTING IT UP AGAINST THE CABLE DIELECTRIC.
- 4.) FLARE THE OUTER SHIELD BRAID BY GENTLY ROTATING THE CONTACT AND DIELECTRIC, THEN FINISH TO FLARE OUT, NOT DISTURBING THE INNER FOIL SHIELD. DO NOT REMOVE THE ALUMINUM MYLAR FOIL INNER SHIELD FROM THE DIELECTRIC. CRIMP CONTACT USING THE .041 HEX DIE OF THE PALADIN TOOL P/N 8049.
- 5.) INSERT THE CONTACT INTO THE REAR OF THE CONNECTOR BODY, THE INNER SHIELD BEING INSIDE OF THE CONNECTOR BODY AND THE BRAID SHIELD OUTSIDE, UNTIL THE CONTACT SNAPS INTO PLACE. SLIDE THE CRIMP TUBE UP OVER THE BRAID AND UP AGAINST THE CONNECTOR BODY. CRIMP FERRULE USING PALADIN TOOL 8049.
- 6.) SLIDE BLACK ADHESIVE HEAT SHRINK UP OVER REAR END OF CONNECTOR BODY (EXCLUDING ARINC CONNECTOR'S) AND HEAT SHRINK. FOR ARINC CONNECTOR'S, SLIDE UP TO REAR OF CONNECTOR BODY AND HEAT SHRINK.

CABLE TYPE	TOOL	HEX SIZE CONTACT	HEX SIZE CRIMP TUBE
PFLX275-075-XX	PALADIN TOOL 8049	0.041	0.278

DATE 02/12/2010	EMTEQ 5349 S. EMMER DRIVE NEW BERLIN, WI 53151 (888) 679-6170			
DRAWN V. LEX				
DESIGNED	CABLE STRIPPING INSTRUCTIONS			
CHECKED <i>[Signature]</i> 02/12/2010				
APPROVED T. FORST	02/12/2010	CAGE CODE 06WH3	DWG # ES-105-65	SHT 1 OF 1

FILE: ES-105-65.prt