

THIS DOCUMENT AND THE INFORMATION IT CONTAINS IS THE PROPERTY OF EMTEQ INC. AND MAY NOT BE USED IN ANY WAY WITHOUT THE EXPRESS WRITTEN CONSENT OF EMTEQ INC.

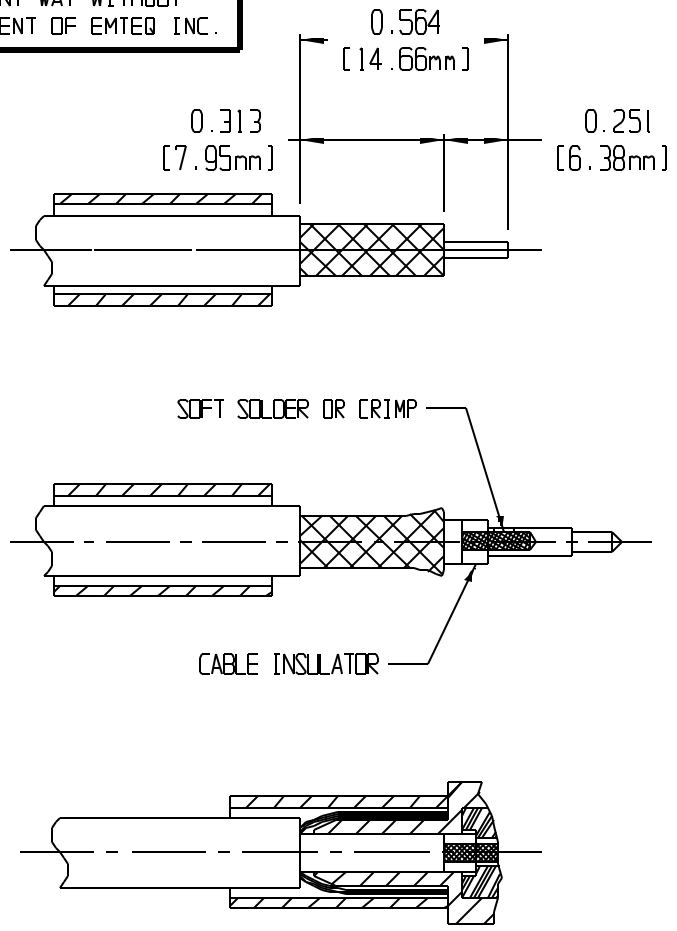

REV	REVISION	DATE	ER #	INTL
A	ADDED TFLX125-075-1	03/19/2009	9507	LLP
A01	ADD CRIMP OPTION FOR CONTACT (NOTE 4)	08/23/2010	11173	VML



ES-105-55
CABLE ASSEMBLY INSTRUCTIONS

- 1.) STRIP CABLE PER DIMENSIONS. DO NOT KNICK THE BRAID OR CENTER CONDUCTOR. SLIDE CRIMP TUBE ONTO CABLE AND PUSH BACK OUT OF WAY BEFORE REMOVING MATERIALS.
- 2.) DO NOT REMOVE THE ALUMINUM MYLAR FOIL SHIELD FROM THE DIELECTRIC.
- 3.) SLIDE BACK ADHESIVE HEAT SHRINK AND ANY OTHER LABELS OVER THE CABLE AT THIS TIME.
- 4.) FLARE END OF CABLE BRAID BY ROTATING CABLE DIELECTRIC. SLIDE CABLE INSULATOR ONTO CENTER CONDUCTOR UP AGAINST DIELECTRIC. SOLDER CONTACT ONTO CENTER CONDUCTOR AS SHOWN. DO NOT OVERHEAT AND SWELL CABLE DIELECTRIC. SEE CHART FOR RECOMMENDED SOLDER TEMPERATURES. CONTACT CAN ALSO BE CRIMPED USING 0.041 OR 0.042 SQUARE DIE.
- 5.) INSTALL CABLE ASSEMBLY INTO BODY ASSEMBLY SO THAT THE TUBE PORTION OF BODY SLIDES UNDER BRAID. PUSH CABLE ASSEMBLY FORWARD UNTIL CONTACT SNAPS INTO POSITION.
- 6.) SLIDE CRIMP TUBE OVER BRAID & UP AGAINST CONNECTOR BODY. CRIMP USING APPROPRIATE HEX SIZE CRIMPING TOOL.

CABLE TYPE	MIL-SPEC HEX DIE P/N	DANIELS HEX DIE P/N	HEX SIZE	SOLDER TEMPERATURE
PFLX175-075-1	M22520/5-41	Y140	A	700-750 ° F (371-398 ° C)
PFLX190-075-1	M22520/5-19(B)	Y142	B	700-750 ° F (371-398 ° C)
TFLX125-075-1	M22520/5-41	Y140	B	700-750 ° F (371-398 ° C)

DATE 03/06/2009		5349 S. EMMER DRIVE NEW BERLIN, WI 53151 (888) 678-6170
DRAWN V. LEX		
DESIGNED	CABLE ASSEMBLY INSTRUCTIONS	
CHECKED  08/25/2010		
APPROVED T. FORST	08/26/2010	CAGE CODE 06WH3
DWG # ES-105-55		SHT 1 OF 1

FILE: ES-105-55.dwt