

THIS DOCUMENT AND THE INFORMATION IT CONTAINS IS THE PROPERTY OF EMTEQ INC. AND MAY NOT BE USED IN ANY WAY WITHOUT THE EXPRESS WRITTEN CONSENT OF EMTEQ INC.

REV	REVISION	DATE	ER #	INTL
B1	UPDATED INSTRUCTION, CHART	10/09/2006	5704	LRL

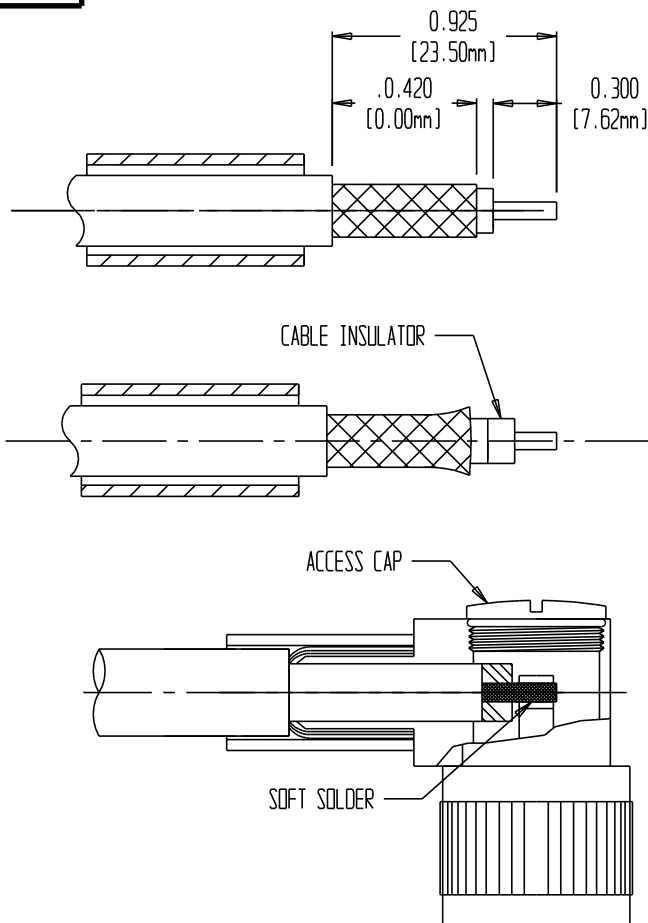

ES-105-5 CABLE ASSEMBLY INSTRUCTIONS

- 1.) SLIDE ON ANY HEAT SHRINK LABELS IF USED, THEN THE BLACK ADHESIVE HEAT SHRINK AND THEN THE CRIMP TUBE.
 - 2.) STRIP THE CABLE PER THE DIMENSIONS SHOWN. BE CAREFUL NOT TO NICK THE CENTER CONDUCTOR OR THE SHIELD BRAID. REMOVE THE MATERIALS. DO NOT REMOVE THE INNER FOIL SHIELD FROM THE DIELECTRIC.
 - 3.) INSTALL THE CABLE INSULATOR ONTO THE CENTER CONDUCTOR BUTTING IT UP AGAINST THE CABLE DIELECTRIC.
 - 4.) TIN THE CENTER CONDUCTOR. FLARE THE OUTER SHIELD BRAID BY GENTLY ROTATING THE CENTER CONDUCTOR AND DIELECTRIC, THEN FINISH TO FLARE OUT, NOT DISTURBING THE INNER FOIL SHIELD. DO NOT REMOVE THE INNER FOIL SHIELD FROM THE DIELECTRIC.
 - 5.) INSERT THE CABLE INTO THE REAR OF THE CONNECTOR BODY, THE INNER FOIL SHIELD BEING INSIDE OF THE CONNECTOR BODY AND THE BRAID SHIELD OVER THE OUTSIDE, INSERTING THE CENTER CONDUCTOR INTO THE SLOT OF THE CONTACT, UNTIL THE CABLE INSULATOR BUTTS AGAINST THE CONTACT.
 - 6.) SOLDER THE CENTER CONDUCTOR TO THE CONTACT. CAUTION: DO NOT OVERHEAT THE CONTACT AND SWELL THE DIELECTRIC AND/OR CABLE INSULATOR. SEE CHART FOR RECOMMENDED SOLDER TEMPERATURES.
 - 7.) SLIDE THE CRIMP TUBE UP OVER THE BRAID AND UP AGAINST THE CONNECTOR BODY. CRIMP USING M22520/5-01 (DANTELS HX4) CRIMPING TOOL WITH APPROPRIATE DIE. SEE CHART.
- * NOTE: WHEN TERMINATING RG-142, RG400 OR PFLX200-XXX, USE THE GOLD CRIMP TUBE SUPPLIED. WHEN TERMINATING PFLX195-500, USE THE SILVER CRIMP TUBE SUPPLIED.
- 8.) ADD "O" RING TO ACCESS CAP, THEN THREAD ON CAP AND TIGHTEN. INSTALL AND HEAT SHRINK THE BLACK ADHESIVE HEAT SHRINK ONTO CONNECTOR, COMPLETELY COVERING THE CRIMP TUBE AND REAR PART OF THE CONNECTOR BODY IF POSSIBLE.

CABLE TYPE	MIL-SPEC HEX DIE P/N	DANTELS HEX DIE P/N	HEX SIDE	SOLDER TEMPERATURE
PFLX175-075-XX	M22520/5-43	Y141	B	700-750 ° F (371-398 ° C)
RG-142 B/U	M22520/5-19	Y142	B	700-750 ° F (371-398 ° C)
PFLX140-XXX	M22520/5-41	Y140	B	700-750 ° F (371-398 ° C)
PFLX195-XXX	M22520/5-19	Y142	B	700-750 ° F (371-398 ° C)
PFLX200-XXX	M22520/5-19	Y142	B	700-750 ° F (371-398 ° C)
PFLX240-XXX	M22520/5-43	Y141	A	700-750 ° F (371-398 ° C)
PFLX340-XXX	M22520/5-35	Y137	A	750-800 ° F (398-427 ° C)
PFLX400-XXX	M22520/5-61	Y178	A	800-850 ° F (427-454 ° C)
PFLX500-XXX	M22520/5-21	Y149	A	800-850 ° F (427-454 ° C)
TFLX125-075-XX	M22520/5-41	Y140	B	700-750 ° F (371-398 ° C)
TFLX130-XXX	M22520/5-41	Y140	B	700-750 ° F (371-398 ° C)
TFLX165-XXX	M22520/5-19	Y142	B	700-750 ° F (371-398 ° C)
TFLX205-XXX	M22520/5-43	Y141	A	700-750 ° F (371-398 ° C)
TFLX225-XXX	M22520/5-43	Y141	A	700-750 ° F (371-398 ° C)
TFLX295-XXX	M22520/5-35	Y137	A	750-800 ° F (398-427 ° C)
TFLX480-XXX	M22520/5-27	Y151	A	800-850 ° F (427-454 ° C)

DATE	03/26/2001
DRAWN	A. SWENSON
DESIGNED	
CHECKED	10/09/2006
T. FORST	
APPROVED	10/09/2006



5349 S. EMMER DRIVE
NEW BERLIN, WI 53151
(888) 679-6170

CABLE STRIPPING INSTRUCTIONS

CAGE CODE	06WH3	DWG #	ES-105-5	SHT	1 OF 1
-----------	-------	-------	----------	-----	--------

FILE: ES-105-5.DWG