

THIS DOCUMENT AND THE INFORMATION IT CONTAINS IS THE PROPERTY OF EMTEQ INC. AND MAY NOT BE USED IN ANY WAY WITHOUT THE EXPRESS WRITTEN CONSENT OF EMTEQ INC.

REV	REVISION	DATE	ER#	INTL
01	UPDATED INSTRUCTION, CHART	10/09/2006	5704	LRL

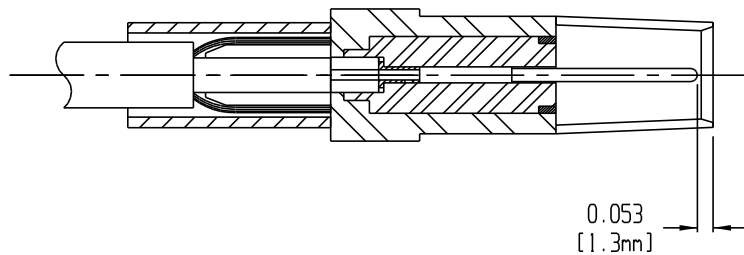

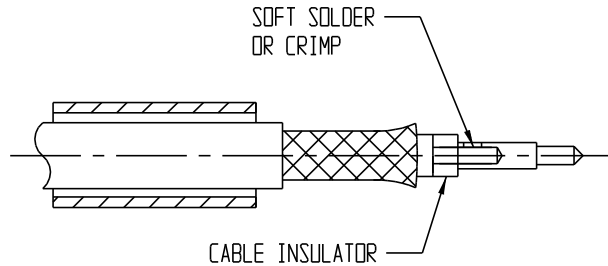
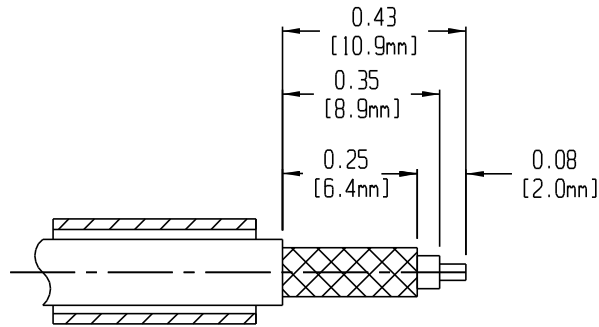

ES-105-34 CABLE ASSEMBLY INSTRUCTIONS

1.) STRIP CABLE TO DIMENSIONS SHOWN. DO NOT KNICK BRAID OR CENTER CONDUCTOR. SLIDE CRIMP TUBE, HEAT SHRINK TUBING, AND ANY LABELS OVER THE CABLE AT THIS TIME.

2.) FLARE END OF CABLE BRAID AS SHOWN. SOLDER CONTACT IN PLACE. AVOID EXCESSIVE HEAT TO PREVENT SWELLING OF DIELECTRIC.

3.) INSTALL CABLE ASSEMBLY INTO BODY ASSEMBLY SO THAT TUBE PORTION OF BODY SLIDES UNDER BRAID. PUSH CABLE ASSEMBLY FORWARD UNTIL CONTACT BOTTOMS OUT IN INSULATOR. CONTACT PRESS FITS INTO INSULATOR. VERIFY CONTACT POSITION BY CHECKING .053 DIMENSION. SLIDE CRIMP TUBE OVER BRAID AND UP AGAINST CONNECTOR BODY. CRIMP USING APPROPRIATE HEX CRIMPING TOOL.

CABLE TYPE	HEX SIZE	P/N	SOLDER TEMPERATURE
PFLX100-075-XX	.128	M22520/5-35	700-750 ° F (371-398 ° C)
PFLX140-XXX	B	M22520/5-41	700-750 ° F (371-398 ° C)

DATE 02/03/2004	 5349 S. EMMER DRIVE NEW BERLIN, WI 53151 (888) 679-6170	CABLE STRIPPING INSTRUCTIONS	SHT 1 of 1
DRAWN V. LEX			
DESIGNED	CABLE STRIPPING INSTRUCTIONS		
CHECKED T. FORST	10/09/2006		
APPROVED 	10/09/2006	CAGE CODE 06WH3	DWG # ES-105-34

FILE: ES-105-34 prt